

Micromite eXtreme Manual

MMBasic Ver 5.3 Beta 10

For updates to this manual and more details on MMBasic
go to <http://geoffg.net/micromite.html>
or <http://mmbasic.com>

The Micromite eXtreme is a new addition to the Micromite family using the 100 and 144-pin PIC32 MZ microcontrollers. The Micromite eXtreme firmware implements all the features of the standard Micromite and the Micromite Plus as described in the *Micromite User Manual* and the *Micromite Plus Manual*. It also has a number of additional features and they are described in this document.

The focus of this manual is to describe just the features that are **unique** to the Micromite eXtreme. For general Micromite programming you should refer to the *Micromite User Manual* and the *Micromite Plus Manual* in addition to this manual.

Contents

Introduction.....	3
Micromite Family Summary	4
Suitable Microcontrollers	5
100-pin Micromite eXtreme Pinouts.....	7
144-pin Micromite eXtreme Pinouts.....	10
Programming the Firmware	14
VGA Driver	14
Mouse Support	16
Unique Micromite eXtreme Features	17

Introduction

This section provides an introduction for users who are familiar with the Micromite and the Micromite Plus and need a summary of the extra features in the Micromite eXtreme.

The Micromite eXtreme is an extension of the standard Micromite and the Micromite Plus; all features of these two versions are also in the Micromite eXtreme. This includes features of the BASIC language, input/output, communications, etc. Some commands have changed slightly (for example the CPU command) but for the main part Micromite programs will run unchanged on the Micromite eXtreme.

The following summarises the new features in the Micromite eXtreme as compared to the standard Micromite and the Micromite Plus:

PIC32 MZ Processor

The Micromite eXtreme is based on the Microchip PIC32MZ 32 bit microcontroller. This chip is available in 100 and 144-pin surface mount packages and is up to five times faster and has up to ten times the program space of the MX series used in the standard Micromite.

High Speed Double Precision Floating Point

The Micromite eXtreme uses the built in hardware floating point capability of the PIC32MZ which is much faster than floating point on the standard Micromite and uses double precision floating point.

I/O Pins

The 100-pin Micromite eXtreme has up to 71 free I/O pins with 40 analog capable and the 144-pin chip has up to 115 free I/O pins with 50 analogue capable. All analogue pins use a 12-bit analogue to digital conversion rather than 10-bit on the standard Micromite.

The Micromite eXtreme has two I²C ports, three SPI ports, six PWM channels and up to four serial COM ports. All serial COM ports are high speed (over 1,000,000 baud).

High Speed LCD Panels

Like the Micromite Plus the Micromite eXtreme supports ten different sized LCD display panels from 1.44" to 8". In addition it can drive displays using the SSD1963 controller in 16-bit parallel mode to achieve an even greater display update speed.

VGA Output

The Micromite eXtreme can drive a VGA display in 640 x 480 pixels with eight colours. All the graphics commands and GUI controls available in the Micromite Plus will also work on the VGA output. The display can also be set to 640x400 format for 16:9 format monitors.

Mouse Input

The Micromite eXtreme can support a PS2 mouse which can be used to activate on screen GUI controls. This feature will work with touch sensitive LCD displays (it works in parallel with the touch sensitivity) but it is especially useful with VGA monitors that do not normally incorporate a touch sensitive surface.

Transparency and BLIT function

On certain LCD display panels or the VGA output the Micromite eXtreme supports transparent text and the BLIT command. These allow text to be written over a background image or graphic items to be moved over the background without erasing or damaging the background.

Sound Output

Using the Micromite Plus you can play stereo WAV files stored on the SD card. You can also generate precise sine waves with selectable frequencies from 1Hz to 20KHz.

Micromite Family Summary

The Micromite Family consists of three major types, the standard Micromite, the Micromite Plus and the Micromite eXtreme. All use the same BASIC interpreter and have the same basic capabilities however they differ in the number of I/O pins, the amount of memory, the displays that they support and their intended use.

- Standard Micromite** Comes in a 28-pin or 44-pin package and is designed for small embedded controller applications and supports small LCD display panels. The 28-pin version is particularly easy to use as it is easy to solder and can be plugged into a standard 28-pin IC socket.
- Micromite Plus** This uses a 64-pin and 100-pin TQFP surface mount package and supports a wide range of touch sensitive LCD display panels from 1.44" to 8" in addition to the standard features of the Micromite. It is intended as a sophisticated controller with easy to create on-screen controls such as buttons, switches, etc.
- Micromite eXtreme** This comes in 100-pin and 144-pin TQFP surface mount packages. The eXtreme version has all the features of the other two Micromites but is faster and has a larger memory capacity plus the ability to drive a VGA monitor for a large screen display. It works as a powerful, self contained computer with its own BASIC interpreter and instant start-up.

	Micromite		Micromite Plus		Micromite eXtreme	
	28-pin DIP	44-pin SMD	64-pin SMD	100-pin SMD	100-pin SMD	144-pin SMD
Maximum CPU Speed	48 MHz	48 MHz	120 MHz	120 MHz	200 MHz	200 MHz
Maximum BASIC Program Size	59 KB	59 KB	100 KB	100 KB	540 KB	540 KB
RAM Memory Size	52 KB	52 KB	108 KB	108 KB	460 KB	460 KB
Clock Speed (MHz)	5 to 48	5 to 48	5 to 120	5 to 120	200	200
Total Number of I/O pins	19	33	45	77	71	115
Number of Analog Inputs	10	13	28	28	40	50
Number of Serial I/O ports	2	2	3 or 4	3 or 4	3 or 4	3 or 4
Number of SPI Channels	1	1	2	2	3	3
Number of I ² C Channels	1	1	1 + RTC	1 + RTC	2 + RTC	2 + RTC
Number of 1-Wire I/O pins	19	33	45	77	45	77
PWM or Servo Channels	5	5	5	5	6	6
Serial Console	✓	✓	✓	✓	✓	✓
USB Console			✓	✓	✓	✓
PS2 Keyboard and LCD Console			✓	✓	✓	✓
SD Card Interface			✓	✓	✓	✓
Supports ILI9341 LCD Displays	✓	✓	✓	✓	✓	✓
Supports Ten LCD Panels from 1.44" to 8" (diameter)			✓	✓	✓	✓
Supports VGA Displays					✓	✓
Sound Output (WAV/tones)			✓	✓	✓	✓
Supports PS2 Mouse Input					✓	✓
Floating Point Precision	Single	Single	Single	Single	Double	Double
Power Requirements	3.3V 30 mA	3.3V 30 mA	3.3V 80 mA	3.3V 80 mA	3.3V 160 mA	3.3V 160 mA

Suitable Microcontrollers

The microcontroller used in the Micromite eXtreme is the PIC32MZ EF series manufactured by Microchip. There are two chip sizes (100-pin and 144-pin) with two frequency specifications (200 MHz and 254 MHz).

The default clock speed of the Micromite eXtreme is 200 MHz however this can be changed with a configuration option to 252 MHz if required. The firmware will automatically adjust for either the 100 or 144 pin version.

The recommended chips are:

PIC32MZ2048EFG100-I/PF	100-pin TQFP package (0.5 mm pin pitch) – maximum speed 200 MHz
PIC32MZ2048EFG144-I/PL	144-pin LQFP package (0.5 mm pin pitch) – maximum speed 200 MHz
PIC32MZ2048EFH100-250I/PF	100-pin TQFP package (0.5 mm pin pitch) – maximum speed 252 MHz
PIC32MZ2048EFH144-250I/PL	144-pin LQFP package (0.5 mm pin pitch) – maximum speed 252 MHz

The chips PIC32MZ2048EFM100-I/PF and PIC32MZ2048EFM144-I/PL can also be used at 200 MHz.

Other packages of the 100-pin (PF) and 144-pin (PH) chips with 0.4mm pin pitch may also be used.

See <http://microchip.com> for the data sheets.

100-pin Test and Development Board

The best development board for the 100-pin 200 MHz chip is the SnadPIC MZ, PIC32MZ EF MCU Starter Kit. This can be ordered with either the PIC32MZ2048EFG100-I/PF or PIC32MZ2048EFH100-I/PF processor (both are similar, the latter has a CAN facility but that is not supported by MMBasic).

If you are developing your own board it would be worth using the SnadPIC board for guidance.

SnadPIC boards can be purchased from:

<http://www.microcontroller-board.com/snadpic-board-32-bit/24-snadpic-mz-pic32mz-ef-mcu-starter-kit-pic32mz2048efg100.html>

or

<http://www.ebay.com.au/itm/PIC32MZ-USB-OTG-Microchip-Development-Board-Starter-kit-SD-Card-SnadPIC-MZ-/181805050475>

or search ebay.com for "SnadPIC MZ"

144-pin Test and Development Board

The website micromite.org is planning to produce a suitable board for the 144-pin chip. This board will mount on the back of a 7" LCD display panel and include connectors for VGA, PS2 keyboard, PS2 mouse and USB.

Check <http://micromite.org/> for details.

Typical Circuit

An example of the required circuit for a Micromite eXtreme is given below:

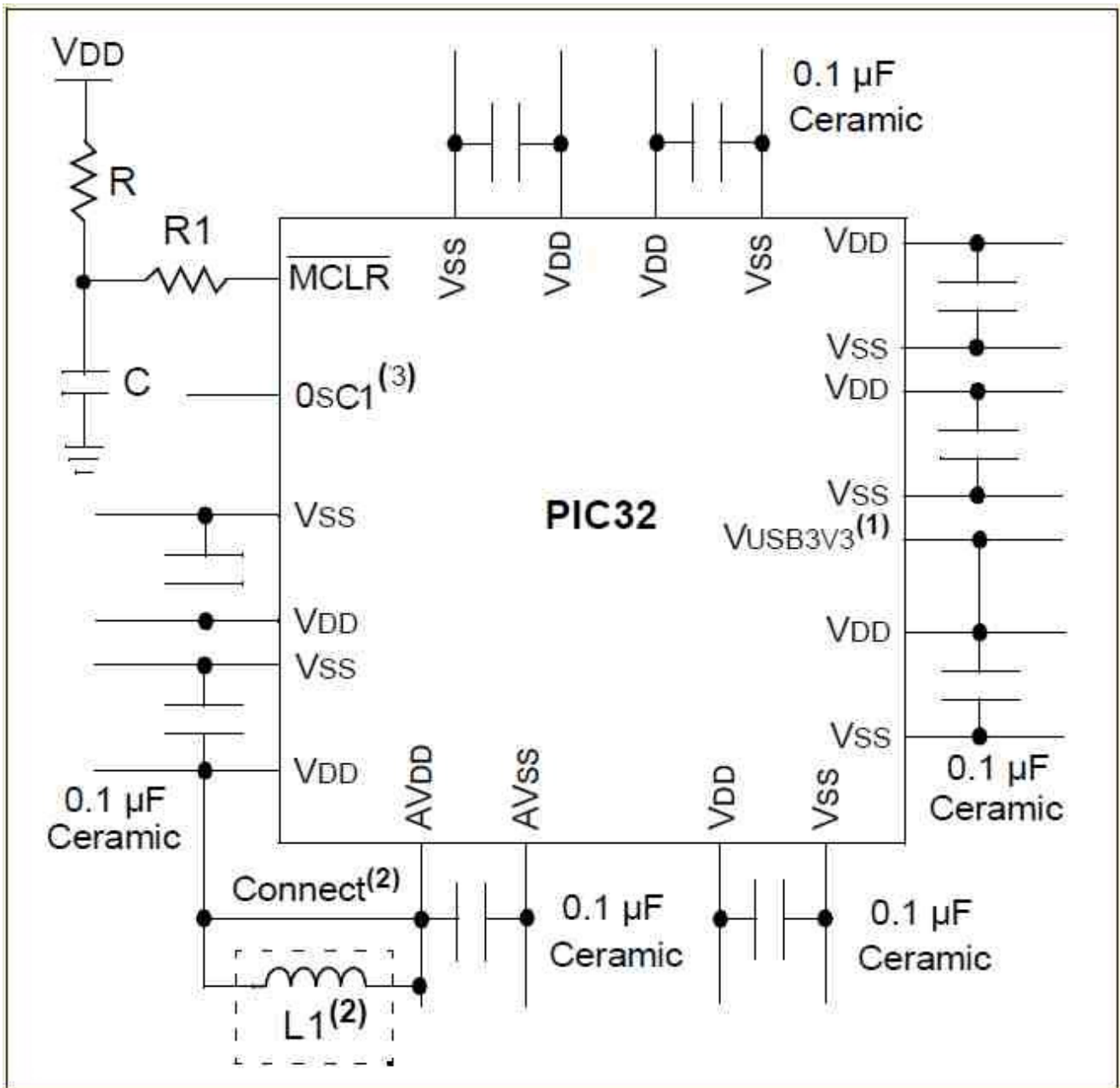

Notes:

1: If the USB module is not used, this pin must be connected to VSS.

2: As an option, instead of a hard-wired connection, an inductor (L1) can be substituted between VDD and AVDD to improve ADC noise rejection. The inductor impedance should be less than 1ohm and the inductor capacity greater than 10 mA.

Alternatively a 10ohm resistor could be substituted for L1

Typical values for R, R1, and C would be 10Kohm, 1Kohm, and 0.1uF

3: A 24MHz crystal oscillator must be connected to the OSC1 pin. e.g. Epson SG8002DCPHB24MHZ
See the pinout below for the pin number

100-pin Micromite eXtreme Pinouts

Pin	Features				
1	ANALOG_IN	DIGITAL_IN	DIGITAL_OUT		
2	ANALOG_IN	DIGITAL_IN	DIGITAL_OUT		
3	ANALOG_IN	DIGITAL_IN	DIGITAL_OUT	PWM-2C	SOUND-LEFT
4	ANALOG_IN	DIGITAL_IN	DIGITAL_OUT		
5	ANALOG_IN	DIGITAL_IN	DIGITAL_OUT		
6	ANALOG_IN	DIGITAL_IN	DIGITAL_OUT	COUNT	PWM-2A
7	ANALOG_IN	DIGITAL_IN	DIGITAL_OUT	COUNT	
8	ANALOG_IN	DIGITAL_IN	DIGITAL_OUT	COUNT	
9	ANALOG_IN	DIGITAL_IN	DIGITAL_OUT	COUNT	IR
10	ANALOG_IN	DIGITAL_IN	DIGITAL_OUT	SPI2-CLK	
11	ANALOG_IN	DIGITAL_IN	DIGITAL_OUT	I2C-SDA	
12	ANALOG_IN	DIGITAL_IN	DIGITAL_OUT	I2C-CLK	
13	VSS				
14	VDD				
15	MCLR				
16	ANALOG_IN	DIGITAL_IN	DIGITAL_OUT	PWM-1C	
17	ANALOG_IN	DIGITAL_IN	DIGITAL_OUT		
18	ANALOG_IN	DIGITAL_IN	DIGITAL_OUT	SOUND-RIGHT	
19	ANALOG_IN	DIGITAL_IN	DIGITAL_OUT	VGA-BLU-SS	
20	ANALOG_IN	DIGITAL_IN	DIGITAL_OUT	SSD1963-D5	
21	ANALOG_IN	DIGITAL_IN	DIGITAL_OUT	SSD1963-D4	VGA-VSYNC
22	ANALOG_IN	DIGITAL_IN	DIGITAL_OUT	SSD1963-D3	
23	ANALOG_IN	DIGITAL_IN	DIGITAL_OUT	SSD1963-D2	
24	ANALOG_IN	DIGITAL_IN	DIGITAL_OUT	SSD1963-D1	
25	ANALOG_IN	DIGITAL_IN	DIGITAL_OUT	SSD1963-D0	
26	ANALOG_IN	DIGITAL_IN	DIGITAL_OUT	SSD1963-D6	
27	ANALOG_IN	DIGITAL_IN	DIGITAL_OUT	SSD1963-D7	
28	ANALOG_IN	DIGITAL_IN	DIGITAL_OUT		
29	ANALOG_IN	DIGITAL_IN	DIGITAL_OUT		
30	AVDD				
31	AVSS				
32	ANALOG_IN	DIGITAL_IN	DIGITAL_OUT	SSD1963-D8	VGA-GRN-OUT
33	ANALOG_IN	DIGITAL_IN	DIGITAL_OUT	SSD1963-D9	VGA-BLU-OUT
34	ANALOG_IN	DIGITAL_IN	DIGITAL_OUT	SSD1963-D10	VGA-RED-OUT
35	ANALOG_IN	DIGITAL_IN	DIGITAL_OUT	SSD1963-D11	
36	VSS				
37	VDD				

38	ANALOG_IN	DIGITAL_IN	DIGITAL_OUT		
39	ANALOG_IN	DIGITAL_IN	DIGITAL_OUT	COM1-EN	VGA-BLU-CLK
40	ANALOG_IN	DIGITAL_IN	DIGITAL_OUT	PWM-2B	
41	ANALOG_IN	DIGITAL_IN	DIGITAL_OUT	SSD1963-D12	
42	ANALOG_IN	DIGITAL_IN	DIGITAL_OUT	SSD1963-D13	
43	ANALOG_IN	DIGITAL_IN	DIGITAL_OUT	SSD1963-D14	VGA-RED-CLK
44	ANALOG_IN	DIGITAL_IN	DIGITAL_OUT	SSD1963-D15	VGA-RED-SS
45	VSS				
46	VDD				
47	ANALOG_IN	DIGITAL_IN	DIGITAL_OUT	COM1-RX	
48	ANALOG_IN	DIGITAL_IN	DIGITAL_OUT	VGA-GRN-CLK	
49	OSC1				
50	OSC2 - unused				
51	VBUS				
52	VDD				
53	VSS				
54	D-				
55	D+				
56	USBID				
57	DIGITAL_IN	DIGITAL_OUT	COM3-TX		
58	DIGITAL_IN	DIGITAL_OUT	COM3-RX		
59	DIGITAL_IN	DIGITAL_OUT	Snadpic-SD-CD	I2C2-CLK	
60	DIGITAL_IN	DIGITAL_OUT	I2C2-SDA		
61	DIGITAL_IN	DIGITAL_OUT			
62	VDD				
63	VSS				
64	DIGITAL_IN	DIGITAL_OUT	VGA-GRN-SS		
65	DIGITAL_IN	DIGITAL_OUT	COM1-TX		
66	DIGITAL_IN	DIGITAL_OUT	SPI2-OUT		
67	DIGITAL_IN	DIGITAL_OUT	SPI3-OUT		
68	DIGITAL_IN	DIGITAL_OUT			
69	DIGITAL_IN	DIGITAL_OUT	SPI3-CLK		
70	DIGITAL_IN	DIGITAL_OUT	SPI3-IN		
71	DIGITAL_IN	DIGITAL_OUT	PWM-1B		
72	DIGITAL_IN	DIGITAL_OUT	SPI2-IN		
73	DIGITAL_IN	DIGITAL_OUT	PWM-1A		
74	VDD				
75	VSS				
76	DIGITAL_IN	DIGITAL_OUT	SPI-CLK		
77	DIGITAL_IN	DIGITAL_OUT	SPI-IN		

78	DIGITAL_IN	DIGITAL_OUT	SPI-OUT	
79	DIGITAL_IN	DIGITAL_OUT	VGA-HSYNC	
80	DIGITAL_IN	DIGITAL_OUT		
81	DIGITAL_IN	DIGITAL_OUT	Snadpic-SD-CS	
82	DIGITAL_IN	DIGITAL_OUT		
83	VDD			
84	VSS			
85	DIGITAL_IN	DIGITAL_OUT	COM4-TX	CONSOLE-TX
86	DIGITAL_IN	DIGITAL_OUT	COM4-RX	CONSOLE-RX
87	DIGITAL_IN	DIGITAL_OUT	COM2-TX	
88	DIGITAL_IN	DIGITAL_OUT	COM2-RX	
89	DIGITAL_IN	DIGITAL_OUT	KBD-CLK	
90	DIGITAL_IN	DIGITAL_OUT	KBD-DAT	
91	DIGITAL_IN	DIGITAL_OUT	MOUSE-CLK	
92	VSS			
93	VDD			
94	DIGITAL_IN	DIGITAL_OUT	MOUSE-DAT	
95	DIGITAL_IN	DIGITAL_OUT	SSD1963-RESET	
96	DIGITAL_IN	DIGITAL_OUT	SSD1963-RS	
97	DIGITAL_IN	DIGITAL_OUT	SSD1963-WR	
98	DIGITAL_IN	DIGITAL_OUT		
99	DIGITAL_IN	DIGITAL_OUT	HEARTBEAT	
100	ANALOG_IN	DIGITAL_IN	DIGITAL_OUT	

144-pin Micromite eXtreme Pinouts

Pin	Features			
1	ANALOG_IN	DIGITAL_IN	DIGITAL_OUT	
2	ANALOG_IN	DIGITAL_IN	DIGITAL_OUT	
3	ANALOG_IN	DIGITAL_IN	DIGITAL_OUT	PWM-2C
4	ANALOG_IN	DIGITAL_IN	DIGITAL_OUT	
5	ANALOG_IN	DIGITAL_IN	DIGITAL_OUT	
6	ANALOG_IN	DIGITAL_IN	DIGITAL_OUT	COUNT3
7	ANALOG_IN	DIGITAL_IN	DIGITAL_OUT	SSD1963-DB8
8	ANALOG_IN	DIGITAL_IN	DIGITAL_OUT	SSD1963-DB9
9	DIGITAL_IN	DIGITAL_OUT	SSD1963-DB12	
10	DIGITAL_IN	DIGITAL_OUT	SSD1963-DB10	
11	ANALOG_IN	DIGITAL_IN	DIGITAL_OUT	COUNT1
12	ANALOG_IN	DIGITAL_IN	DIGITAL_OUT	COUNT2
13	ANALOG_IN	DIGITAL_IN	DIGITAL_OUT	COUNT4-IR
14	ANALOG_IN	DIGITAL_IN	DIGITAL_OUT	SPI2 CLK
15	ANALOG_IN	DIGITAL_IN	DIGITAL_OUT	I2C-SDA
16	ANALOG_IN	DIGITAL_IN	DIGITAL_OUT	I2C-CLK
17	GND			
18	VCC			
19	DIGITAL_IN	DIGITAL_OUT	HEARTBEAT	
20	RESET			
21	ANALOG_IN	DIGITAL_IN	DIGITAL_OUT	
22	ANALOG_IN	DIGITAL_IN	DIGITAL_OUT	
23	ANALOG_IN	DIGITAL_IN	DIGITAL_OUT	COM1-EN
24	ANALOG_IN	DIGITAL_IN	DIGITAL_OUT	VGA-HSYNC
25	ANALOG_IN	DIGITAL_IN	DIGITAL_OUT	
26	ANALOG_IN	DIGITAL_IN	DIGITAL_OUT	VGA-VSYNC
27	ANALOG_IN	DIGITAL_IN	DIGITAL_OUT	SSD1963-DB11
28	DIGITAL_IN	DIGITAL_OUT	SSD1963-DB13	
29	DIGITAL_IN	DIGITAL_OUT	SSD1963-DB14	
30	DIGITAL_IN	DIGITAL_OUT	SSD1963-DB15	
31	ANALOG_IN	DIGITAL_IN	DIGITAL_OUT	
32	GND			
33	VCC			
34	ANALOG_IN	DIGITAL_IN	DIGITAL_OUT	SOUND-LEFT
35	ANALOG_IN	DIGITAL_IN	DIGITAL_OUT	SOUND-RIGHT
36	ANALOG_IN	DIGITAL_IN	DIGITAL_OUT	
37	ANALOG_IN	DIGITAL_IN	DIGITAL_OUT	

38	ANALOG_IN	DIGITAL_IN	DIGITAL_OUT	
39	ANALOG_IN	DIGITAL_IN	DIGITAL_OUT	
40	ANALOG_IN	DIGITAL_IN	DIGITAL_OUT	
41	AVDD			
42	AVSS			
43	ANALOG_IN	DIGITAL_IN	DIGITAL_OUT	
44	ANALOG_IN	DIGITAL_IN	DIGITAL_OUT	
45	DIGITAL_IN	DIGITAL_OUT		
46	DIGITAL_IN	DIGITAL_OUT		
47	ANALOG_IN	DIGITAL_IN	DIGITAL_OUT	VGA-GRN-OUT
48	ANALOG_IN	DIGITAL_IN	DIGITAL_OUT	VGA-BLU-OUT
49	ANALOG_IN	DIGITAL_IN	DIGITAL_OUT	VGA-RED-OUT
50	ANALOG_IN	DIGITAL_IN	DIGITAL_OUT	
51	DIGITAL_IN	DIGITAL_OUT		
52	DIGITAL_IN	DIGITAL_OUT		
53	DIGITAL_IN	DIGITAL_OUT		
54	GND			
55	VCC			
56	ANALOG_IN	DIGITAL_IN	DIGITAL_OUT	
57	ANALOG_IN	DIGITAL_IN	DIGITAL_OUT	VGA-CLK
58	ANALOG_IN	DIGITAL_IN	DIGITAL_OUT	PWM-2B
59	ANALOG_IN	DIGITAL_IN	DIGITAL_OUT	
60	ANALOG_IN	DIGITAL_IN	DIGITAL_OUT	
61	ANALOG_IN	DIGITAL_IN	DIGITAL_OUT	VGA-CLK
62	ANALOG_IN	DIGITAL_IN	DIGITAL_OUT	VGA-HSYNC
63	GND			
64	VCC			
65	ANALOG_IN	DIGITAL_IN	DIGITAL_OUT	
66	ANALOG_IN	DIGITAL_IN	DIGITAL_OUT	
67	ANALOG_IN	DIGITAL_IN	DIGITAL_OUT	
68	DIGITAL_IN	DIGITAL_OUT		
69	ANALOG_IN	DIGITAL_IN	DIGITAL_OUT	COM1-RX
70	ANALOG_IN	DIGITAL_IN	DIGITAL_OUT	VGA-CLK
71	OSC1			
72	OSC2 - unused			
73	VBUS			
74	VCC			
75	GND			
76	USB-			
77	USB+			

78	USBID		
79	DIGITAL_IN	DIGITAL_OUT	COM3-TX
80	DIGITAL_IN	DIGITAL_OUT	COM3-RX
81	DIGITAL_IN	DIGITAL_OUT	
82	DIGITAL_IN	DIGITAL_OUT	
83	DIGITAL_IN	DIGITAL_OUT	
84	DIGITAL_IN	DIGITAL_OUT	
85	DIGITAL_IN	DIGITAL_OUT	I2C2-SCK
86	DIGITAL_IN	DIGITAL_OUT	I2C2-SDA
87	DIGITAL_IN	DIGITAL_OUT	
88	VCC		
89	GND		
90	DIGITAL_IN	DIGITAL_OUT	VGA-HSYNC
91	DIGITAL_IN	DIGITAL_OUT	COM1-TX
92	DIGITAL_IN	DIGITAL_OUT	
93	DIGITAL_IN	DIGITAL_OUT	
94	DIGITAL_IN	DIGITAL_OUT	
95	DIGITAL_IN	DIGITAL_OUT	SPI2-OUT
96	DIGITAL_IN	DIGITAL_OUT	SPI3-OUT
97	DIGITAL_IN	DIGITAL_OUT	
98	DIGITAL_IN	DIGITAL_OUT	SPI3-CLK
99	DIGITAL_IN	DIGITAL_OUT	SPI3-IN
100	DIGITAL_IN	DIGITAL_OUT	
101	DIGITAL_IN	DIGITAL_OUT	
102	DIGITAL_IN	DIGITAL_OUT	
103	DIGITAL_IN	DIGITAL_OUT	
104	DIGITAL_IN	DIGITAL_OUT	PWM-1B
105	DIGITAL_IN	DIGITAL_OUT	SPI2-IN
106	DIGITAL_IN	DIGITAL_OUT	PWM-1A
107	VCC		
108	GND		
109	DIGITAL_IN	DIGITAL_OUT	SPI-CLK
110	DIGITAL_IN	DIGITAL_OUT	SPI-IN
111	DIGITAL_IN	DIGITAL_OUT	SPI-OUT
112	DIGITAL_IN	DIGITAL_OUT	VGA-HSYNC
113	DIGITAL_IN	DIGITAL_OUT	
114	DIGITAL_IN	DIGITAL_OUT	SSD1963-DB0
115	DIGITAL_IN	DIGITAL_OUT	SSD1963-DB1
116	DIGITAL_IN	DIGITAL_OUT	SSD1963-DB2
117	DIGITAL_IN	DIGITAL_OUT	SSD1963-DB3

118	DIGITAL_IN	DIGITAL_OUT		
119	DIGITAL_IN	DIGITAL_OUT	PWM-1C	
120	DIGITAL_IN	DIGITAL_OUT	PWM-2A	
121	DIGITAL_IN	DIGITAL_OUT		
122	VCC			
123	GND			
124	DIGITAL_IN	DIGITAL_OUT	Console-TX	COM4-TX
125	DIGITAL_IN	DIGITAL_OUT	Console-RX	COM4-RX
126	DIGITAL_IN	DIGITAL_OUT		
127	DIGITAL_IN	DIGITAL_OUT	COM2-TX	
128	DIGITAL_IN	DIGITAL_OUT	COM2-RX	
129	DIGITAL_IN	DIGITAL_OUT	KB-CLK	
130	DIGITAL_IN	DIGITAL_OUT	KB-DAT	
131	DIGITAL_IN	DIGITAL_OUT	SSD1963-DB4	
132	DIGITAL_IN	DIGITAL_OUT	SSD1963-DB5	
133	DIGITAL_IN	DIGITAL_OUT	SSD1963-DB6	
134	DIGITAL_IN	DIGITAL_OUT	SSD1963-DB7	
135	DIGITAL_IN	DIGITAL_OUT	MOUSE-CLK	
136	GND			
137	VCC			
138	DIGITAL_IN	DIGITAL_OUT	MOUSE-DAT	
139	DIGITAL_IN	DIGITAL_OUT		
140	DIGITAL_IN	DIGITAL_OUT		
141	DIGITAL_IN	DIGITAL_OUT		
142	DIGITAL_IN	DIGITAL_OUT		
143	DIGITAL_IN	DIGITAL_OUT		
144	ANALOG_IN	DIGITAL_IN	DIGITAL_OUT	

Programming the Firmware

Programming the 100 and 144-pin Micromite eXtreme is similar to programming the 28-pin standard Micromite described in the Micromite User Manual.

Refer to the following table for the pin connections to a PICKit 3 programmer:

PICKit 3 Pins	Description	100-pin Micromite eXtreme pin numbers	144-pin Micromite eXtreme pin numbers
1-MCLR	Master Reset (active low)	15	20
2-Vcc	Power Supply (3.3V)	14, 37, 46, 62, 74, 83, 93, 30 (AVDD), 52 (VUSB3V3)	18, 33, 55, 64, 88, 107, 122, 137, 41 (AVDD), 74 (VUSB3V3)
3-GND	Ground	13, 36, 45, 53, 63, 75, 84, 92, 31 (AVSS)	17, 32, 54, 63, 75, 89, 108, 123, 136, 42(AVSS)
4-PGD	Programming Data	25 or 27	36 or 38
5-PGC	Programming Clock	24 or 26	35 or 37
6-NC	Not used		

Notes:

- PDD/PGC must be used in matched pairs as aligned vertically in the table
- A pullup resistor of 10K is required between MCLR and Vcc.
- An oscillator is not required to program these chips and will be ignored if present
- The microcontroller being programmed can be powered by the PICKit 3 but it is recommended that a separate power supply be used. When the PICKit 3 supplies the power pin 2 (Vcc) on the PICKit 3 will become an output supplying power to the chip being programmed

VGA Driver

The Micromite eXtreme can drive a standard VGA monitor by internally generating the necessary VGA signals (red, green, sync, etc). When a VGA monitor is connected and configured the VGA output works exactly the same as a connected LCD display panel – this means that all graphics commands, GUI objects, etc can be used as described in the Micromite and Micromite Plus manuals.

The features of the VGA driver are:

- 640 x 480 pixel output
- Optional 640 x 400 widescreen output
- Eight colours (red, blue, green, cyan, magenta, black, white)
- Works with all graphics and GUI commands.
- Supports any command/features that use transparency (transparent text and the BLIT command).
- Works as the console with 80 characters x 36 lines
- Supported by the EDIT command

VGA Connections

The connections for the VGA monitor are shown below:

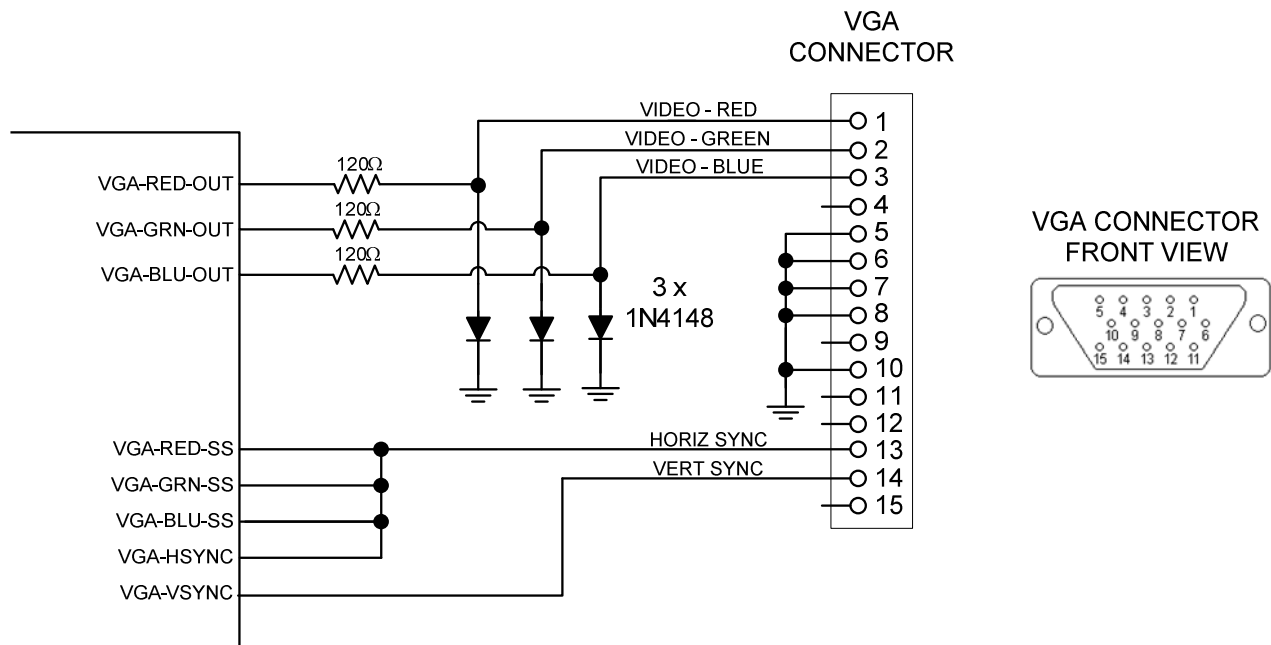

The I/O pins VGA-RED-CLK, VGA-GRN-CLK, VGA-BLU-CLK must be left unconnected.

For the actual pin numbers refer to the pinout tables earlier in this manual.

Note that the diodes must be high speed signal types like the 1N4148 (not general purpose power diodes).

Configuring VGA Output

The command to enable the standard VGA 640 x 480 pixel output is:

```
OPTION LCDPANEL VGA
```

and to enable the widescreen format (640 x 400 pixels) the command is:

```
OPTION LCDPANEL VGA, 16
```

These commands only needs to be run once as the parameters are stored in non volatile memory. Every time the Micromite is restarted MMBasic will automatically initialise the display ready for use. If the VGA output is no longer required the command `OPTION LCDPANEL DISABLE` can be used which will disable the VGA feature and return the I/O pins for general use.

If the VGA monitor is also to be used as the console the normal command can be used to enable this:

```
OPTION LCDPANEL CONSOLE
```

Mouse Support

The Micromite eXtreme supports a PS2 mouse which will act like a touch input on an LCD screen (it also works with the VGA output). MMBasic will automatically display a mouse pointer on the display which is moved by the mouse. When the left button the mouse is clicked it will act like a touch at the location pointed to by the cursor. This feature will also work with GUI controls.

Connecting the Mouse

The PS2 mouse uses a 6-pin DIN connector which should be connected to the Micromite eXtreme as illustrated.

To enable the mouse the command is:

OPTION MOUSE ENABLE

and to disable it:

OPTION MOUSE DISABLE

These commands only needs to be run once as the parameters are stored in non volatile memory. Every time the Micromite is restarted MMBasic will automatically initialise the mouse input ready for use.

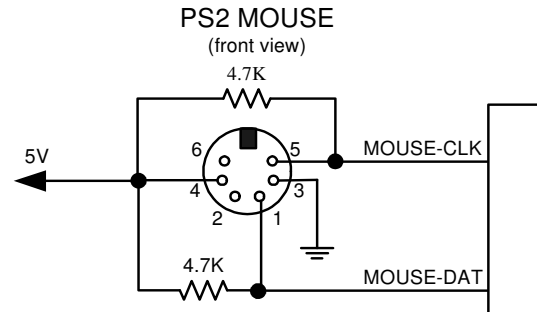

Cursor Commands

The cursor (ie, mouse pointer) can be turned off/on, its colour can be set and its status can be overridden using the CURSOR command. It will only work with displays that support transparency. Displays capable of transparent text are a VGA monitor or any LCD panels that use the ILI9341 controller or an SSD1963 controller. The latter must have the RD pin specified in the OPTION LCDPANEL command. The cursor command can be used without a mouse to allow, for example, a joystick to move the cursor.

The cursor commands are as follows:

CURSOR ON

Enables the display of the cursor (this is the default when MOUSE is first enabled). If it is used after a previous CURSOR OFF command it will also restore the previous position of the cursor.

CURSOR OFF

Hides the cursor.

CURSOR X, Y [, LEFT] [, RIGHT] [, MID]

Positions the cursor to the screen location X and Y (in pixels) and sets the left-click (0 or 1) and optionally the right-click and mid-click status.

CURSOR COLOUR colour

Sets the cursor colour (this is a standard 24-bit colour value). CURSOR COLOR (US spelling) is also valid.

Cursor Functions

CURSOR(x)

Returns the current x coordinate (in pixels) of the cursor

CURSOR(y)

Returns the current y coordinate (in pixels) of the cursor

CURSOR(left)

Returns the current state of the left button

CURSOR(right)

Returns the current state of the right button

CURSOR(middle)

Returns the current state of the middle button

Unique Micromite eXtreme Features

Double Precision Floating Point

The Micromite eXtreme uses the hardware floating point compatibility of the MZ series of chips and can therefore process floating point calculations faster than the Micromite and Micromite Plus. All floating point uses double precision calculations.

Nothing is required to enable this feature, it is automatically available.

Clock Speed Control

MMBasic can work with chips rated for 200 MHz or 252 MHz operation. By default the firmware will start running at 200 MHz however the 252 MHz clock speed can be selected with the command:

```
OPTION CPU 252
```

or the speed can be returned to 200 MHz with the command:

```
OPTION CPU 200
```

These commands change how MMBasic starts up and will cause a restart of the processor. The clock speed is saved in flash memory so the command only needs to be used once and will be automatically applied on startup.

OPTION CPU 252 must only be used on chips specifically rated for 250Mhz operation. Use on a 200MHz rated chip won't work and the chip will need to be re-flashed with the Micromite eXtreme firmware.

Apart from the increased processing speed the only difference at 252 Mhz is the ability to use WAV files recorded at 24 Khz and 48 Khz

16-bit Interface to SSD1963 Based LCD Displays

The Micromite eXtreme can drive a SSD1963 display using a 16-bit parallel bus for extra speed. The extra I/O pins for this are listed as SSD1963-DB8 to SSD1963-DB15 on the pinout tables in this manual and they must be connected to the pins labelled DB8 to DB15 on the I/O connector on the SSD1963 display.

Note that in this mode the SSD1963 controller runs with a reduce colour range (65 thousand colours) compared to 16 million colours with the normal 8-bit interface.

To select the 16-bit bus the following controller names must be used with the OPTION LCDPANEL command when configuring the display:

- SSD1963_4_16 For a 4.3 inch display
- SSD1963_5_16 For a 5 inch display
- SSD1963_5A_16 For an alternative version of the 5 inch display if SSD1963_5 does not work
- SSD1963_7_16 For a 7 inch display
- SSD1963_7A_16 For an alternative version of the 7 inch display if SSD1963_7 does not work.
- SSD1963_8_16 For an 8 inch display.

GETSCANLINE Function

The GETSCANLINE() function can be used with displays using the SSD1963 controller to determine the line that the controller is writing to at that instant. Using this feature it is possible to update the display without causing a flicker by waiting until the controller is updating another area of the display before changing the graphics on a particular part of the display. It can be used like this:

```
if GETSCANLINE() > XCoord + MM.FontHeight THEN TEXT 0, XCoord, ...
```

Two I²C Channels

The Micromite eXtreme supports two I²C channels. The second channel operates the same as the first, the only difference is that the commands use the notation I2C2 (for example I2C2 OPEN, etc).

Three SPI Channels

The Micromite eXtreme supports three SPI channels. The second and third channels operate the same as the first, the only difference is that the commands use the notation SPI2 and SPI3 (for example SPI3 WRITE, etc).

Note that by default, if the Micromite eXtreme is configured for a SPI based LCD panel, touch or an SD card then SPI2 will be unavailable to BASIC programs as these functions will use that channel.

Alternate SPI Channel for the SD Card

The SPI channel used for the SD Card (if configured) defaults to the second channel (SPI2) however this can be changed by appending the SPI channel number to the end of the OPTION SDCARD command this:

```
OPTION SDCARD CSPIN [,CDPIN] [,WPPIN] [,SPIno]
```

'SPIno' is the SPI controller to use and can be 1, 2 or 3.

This is particularly useful with the SnadPIC MZ, PIC32MZ EF MCU Starter Kit is as it has the SD Card hardwired to controller 3. In that case the MMBasic command to configure the SD Card would be:

```
OPTION SDCARD 81, 59, , 3
```

Six PWM Channels

The second PWM controller (ie, PWM 2) supports three channels (the other versions of the Micromite only support two). The command to use all three channels is:

```
PWM 2, freq, 2A, 2B, 2C
```

Similarly the SERVO command can also control six channels with the extra channel available on controller 2:

```
SERVO 2 [, freq], 2A, 2B, 2C
```

Heartbeat

The heartbeat is an I/O pin which is pulsed off and on at a 1Hz rate. It is normally used to drive a LED to show that MMBasic is alive and running on the Micromite eXtreme.

The default is for it to be enabled however it can be disabled with:

```
OPTION HEARTBEAT DISABLE
```

If necessary it can be re enabled with:

```
OPTION HEARTBEAT ENABLE
```

These commands only needs to be run once as the parameters are stored in non volatile memory. Every time the Micromite is restarted MMBasic will automatically initialise the heartbeat feature.

Extended WAV File Playback

The Micromite eXtreme can play WAV files (like the Micromite Plus) however, if the eXtreme is configured to run at 252 Mhz it is also capable of playing WAV files recorded with sampling rates of 24 KHz and 48 KHz.

Random Number Generation

The Micromite eXtreme uses the hardware random number generator in the MZ series of chips to deliver true random numbers. This means that the RANDOMIZE command is no longer needed and is not supported.

MM.DEVICE\$

On the Micromite eXtreme the read only variable MM.DEVICE\$ will return "Micromite eXtreme".

CPU command

The Micromite eXtreme does not support dynamically changing the CPU speed or the sleep function. Accordingly the commands CPU speed and CPU SLEEP are not available. It does support "CPU SLEEP time" where time is specified in seconds. Do not use OPTION CPU 252 on anything other than a PIC32MZ2048EFH100-250 PIC32MZ2048EFH1144-250 chip or otherwise the firmware will need to be reloaded.

The CPU speed of the Micromite eXtreme can be permanently set to 200 MHz or 252 MHz using the OPTION CPU command.

OPTION CONTROLS command

The Micromite eXtreme does not support the OPTION CONTROLS command instead the maximum number of GUI controls is set to 250.